



HEIGHT ADJUSTABLE TABLE

USER GUIDE

TABLE OF CONTENTS

Parts Diagram	3-6
Independent	3
Independent with HAT Channel	4
Three-Leg: 90 Degree	5
Three-Leg: 120 Degree	6
Safety Information	7-8
Assembly Instructions	9-14
Operation	15-17
Initialization/Reset	15
Handswitch Operation	15
Programmable Handswitch Operation	15-16
- Change the Height Unit	16
- Change the Height Display	16
- Save Memory Position	16
- Recall Memory Position	16
Sensitivity Adjustment for External Collision Sensor	16
Shelf and Container Stops	17
- Set up Shelf and Container Stop	17
- Delete the Container Stop	17
- Delete the Shelf Stop	17
Troubleshooting	18-21
Unit Errors	18
Accoustic Codes	19
Visual Codes	20-21
Technical Data	22
Warranty	23
Standards & Certifications	23

This manual explains how this sit-stand desk is assembled, used, and maintained. All sit-stand tables are subjected to functional and quality tests before leaving our facility.

PARTS

INDEPENDENT

For tables 60" or Less

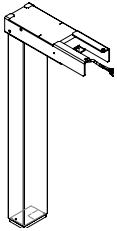

Column (2)

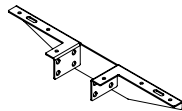

Top Support (2)

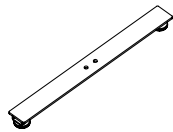

Foot (2)

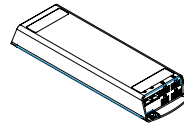

Control Box (1)

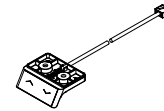

Handswitch (1)

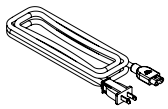

Power Cord (1)



#10 x 3/4 Screw (32)



M8x1.25 12mm

Self-Threading Screw (8)



M10x1.5

30mm Screw (4)

PARTS

INDEPENDENT WITH HAT CHANNEL

For tables 60"-84"

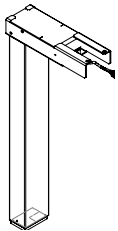

Column (2)

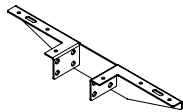

Top Support (2)

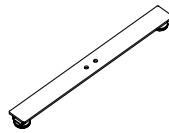

Foot (2)

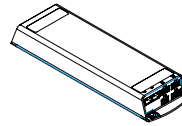

Control Box (1)

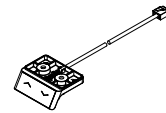

Handswitch (1)

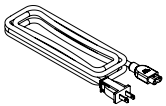

Power Cord (1)

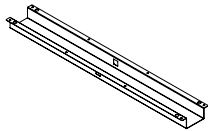

HAT Channel (1)



#10 x 3/4 Screw (40)



**M8x1.25 12mm
Self-Threading Screw (8)**



**M10x1.5
30mm Screw (4)**

PARTS

THREE-LEG: 90 DEGREE

For tables up to 72"

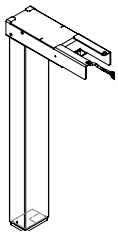

Column (3)

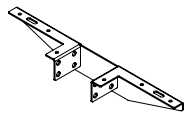

Top Support (3)

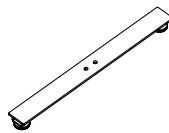

Foot (3)

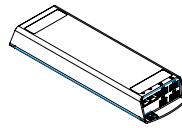

Control Box (1)

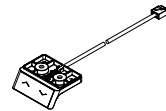

Handswitch (1)

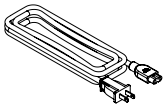

Power Cord (1)

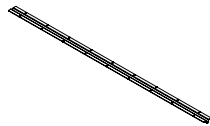

Anti-Sag Bar (2)



**#10 x 3/4 Screw
(68-88)**



**M8x1.25 12mm
Self-Threading Screw (12)**



**M10x1.5
30mm Screw (4)**

PARTS

THREE-LEG: 120 DEGREE

For tables up to 60"

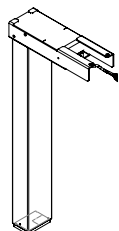

Column (3)

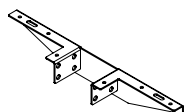

Top Support (3)

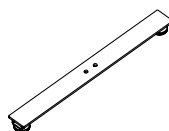

Foot (3)

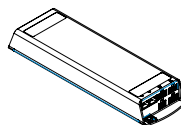

Control Box (1)

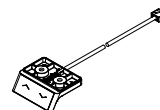

Handswitch (1)

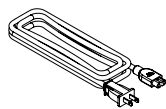

Power Cord (1)

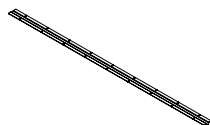

Anti-Sag Bar (2)



**#10 x $\frac{3}{4}$ Screw
(52-64)**



**M8x1.25 12mm
Self-Threading Screw (12)**



**M10x1.5
30mm Screw (4)**

SAFETY INFORMATION

IMPORTANT SAFETY INSTRUCTIONS *Save these instructions.*

DANGER To reduce the risk of electric shock:

Always unplug the furnishing from the electrical outlet before cleaning or servicing.

WARNING: Risk of Electric Shock, Fire and Injury – Review the assembly instructions to confirm that the appropriate critical components and accessories are being used with the furnishing. Do not change or replace components and accessories provided by the manufacturer.

INSTALL ONLY APPROVED WORK SURFACES

This table system does not include a work surface (desktop). Work surface must be at least $\frac{3}{4}$ " thick and weigh no more than 5 lb. per square foot (For example, a 2'x6' desktop should weigh no more than 60 lb). Do not exceed a maximum weight for the desktop of 75 lb. To prevent table from tipping or collapsing, make sure the desk frame is not overloaded by the weight of tabletop and objects you plan to put on the table. If you are unsure, contact customer service.

KEEP AWAY FROM CHILDREN

This table system is not designed for use in homes or other areas accessible by small children. For indoor commercial office use only.

BE CAREFUL WHEN ADJUSTING DESK HEIGHT

Body parts and property can be caught between the moving work surface and an immobile obstacle (such as shelves, furniture, window sills, or walls). Keep at least one inch of clearance around desk and make sure nothing is in table's path for its entire range of motion.

Before raising or lowering:

- Check surroundings on all sides of desk are clear
- Make sure corded objects will not be pulled off table or cause other objects to fall
- Make sure desk power cord moves freely as desk moves up and down

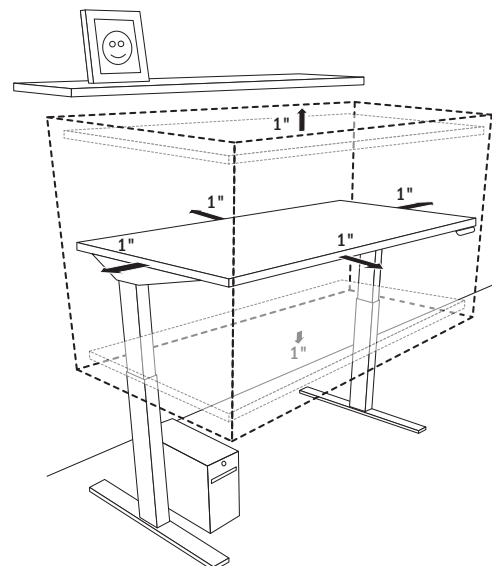

DO NOT OVERLOAD DESK

To prevent table from tipping or collapsing, make sure the desk frame is not overloaded by the weight of tabletop and objects on table. Evenly distribute load; excess loads near edges can reduce stability and lead to tip over.

- Do not exceed maximum load (including weight of desktop) of 200 lb. (91Kg) for two-leg configuration, and 250 lb. (113 Kg) for three-leg configuration
- Do not exceed edge load of 25 lb. when positioning monitors or mounting accessories.
- Do not sit or stand on table

USE CARE WHEN MOVING DESK

- Clear objects and equipment from table before moving to reduce the risk of tipping over.
- Adjust the desk to its lowest height before moving
- To disconnect, remove plug from outlet
- Do not move a loaded desk

DO NOT OPEN ELECTRICAL COMPONENTS

Do not attempt to service table components. There are no user-serviceable parts inside the motor control units or table legs. If your table needs service, contact customer service. Never operate this workstation if it has a damaged cord or plug.

KEEP TABLE FRAME DRY

Keep all electrical components away from water and high humidity. Clean only with a dry or slightly damp cloth. Do not spray cleaning solutions directly onto table system.

GROUNDING INSTRUCTIONS

This product may be equipped with a cord having an equipment-grounding conductor and a grounding plug. **Use only the cord provided.** Make sure that the product is connected to an outlet having the same configuration as the plug (as shown in Illustration A) that is properly installed and grounded in accordance with all local codes and ordinances.

Do not modify the plug provided with the product – if it will not fit the outlet, have a proper outlet installed by a qualified electrician.

No adapters are to be used with this product.
Keep cord away from heated surfaces.

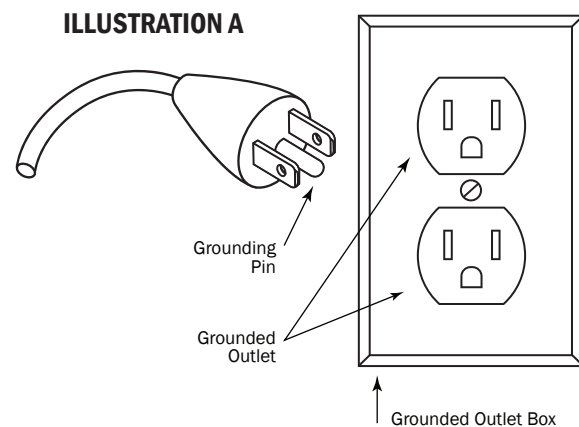

ASSEMBLY INSTRUCTIONS

The assembly of the table frame to be made in accordance with this manual. Changes to the table frame or improper use may affect the safety, function, and life of your product.

*This manual is for all sit-stand tables from the series.
Due to different models or types, pictures may vary.*

ASSEMBLY OVERVIEW

1. Fasten the top support onto the table top
2. Assemble the beam and column to the top support
3. Assemble the foot to the column
4. Fasten the table frame onto the table top
5. Fasten the control box and handswitch to the table top
6. Connect the motor cables to the control box
7. Connect the handswitch (HS) cable to the control box
8. Connect the supplied power cord (AC) to the control box
9. Attach all cables to the table frame or on the underside of the table top

DO NOT remove the foam surrounding the motor.

If you have any difficulty assembling this unit, or need to order replacement parts, please contact our Customer Service department. Use the parts diagrams on page 3-6 as a reference.

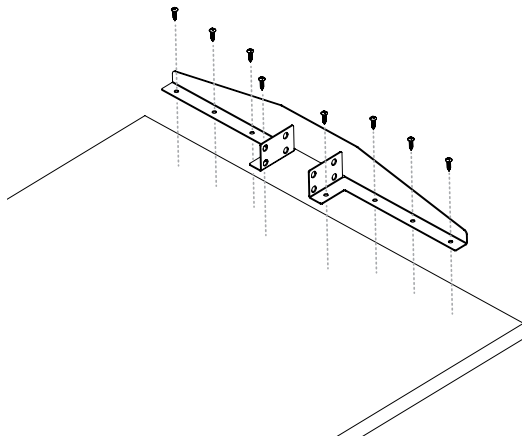

1 FASTEN THE TOP SUPPORT ONTO THE TABLE TOP

Be sure top supports are mounted 1.5" from edge of work surface.

2 ASSEMBLE THE BEAM AND COLUMN TO THE TOP SUPPORT

Align the independent beam to the top support. Assemble using the M8x1.25 x 12mm length screws (4 per column) and a T40 Torx driver. Be aware that the mounting holes may not be tapped. As they are inserted, the provided M8x1.25 x 12mm length screws will form their own fastening threads if none are already present. An average fastening torque of 8Nm (6 lbs-ft) will be required to initially engage the screw in the hole. The maximum tightening torque for these screws is 15Nm (11 lbs-ft). Repeat as necessary for remaining columns.

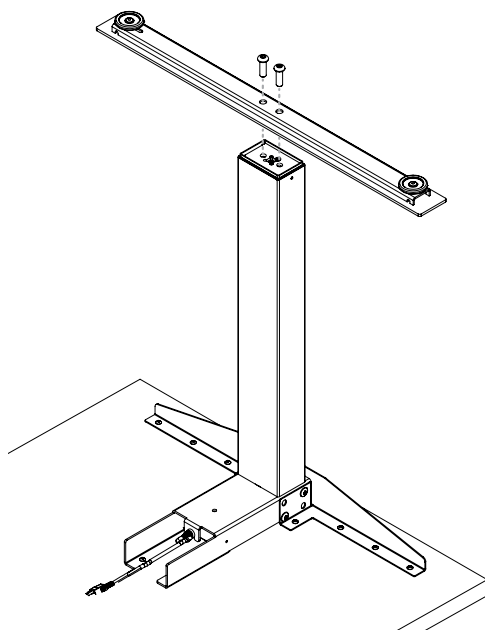
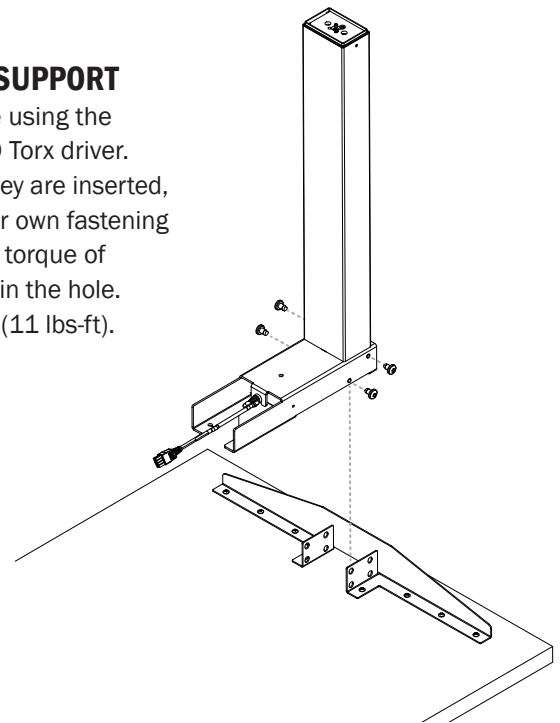

3 ASSEMBLE THE FOOT TO THE COLUMN

Assemble using the M10x1.5 x 30mm length screws (2 per column). The maximum tightening torque for these screws is 11Nm (8.1ft-lbs). In the absence of a torque wrench, use fingers to twist the bolts into position. Then apply an additional $\frac{1}{4}$ (90°) turn to each bolt with an M6 Hex drive. Note, each bolt should be tightened once. Do not retorquing the first bolt after torquing the last

4 FASTEN THE INDEPENDENT BEAM TO THE TABLE TOP

Be sure to use approved screws per the table top supplier.

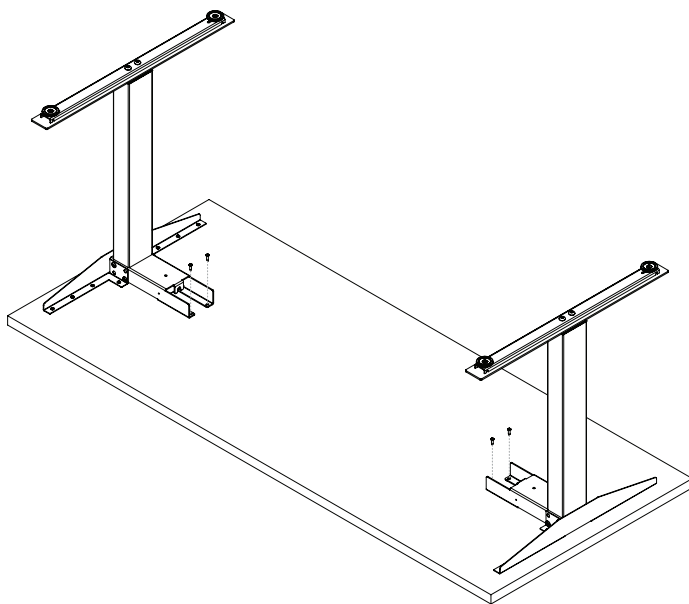

INDEPENDENT*

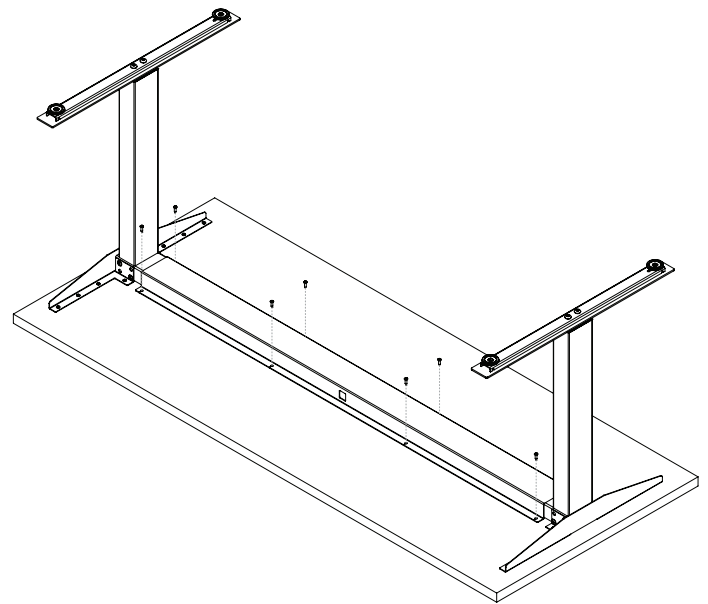

INDEPENDENT WITH HAT CHANNEL*

Note: Feed the motor cables through the HAT channel before attaching the HAT channel to the tabletop.

*Please make sure top supports are mounted 1.5" from edge of work surface.

THREE-LEG: 90 DEGREE

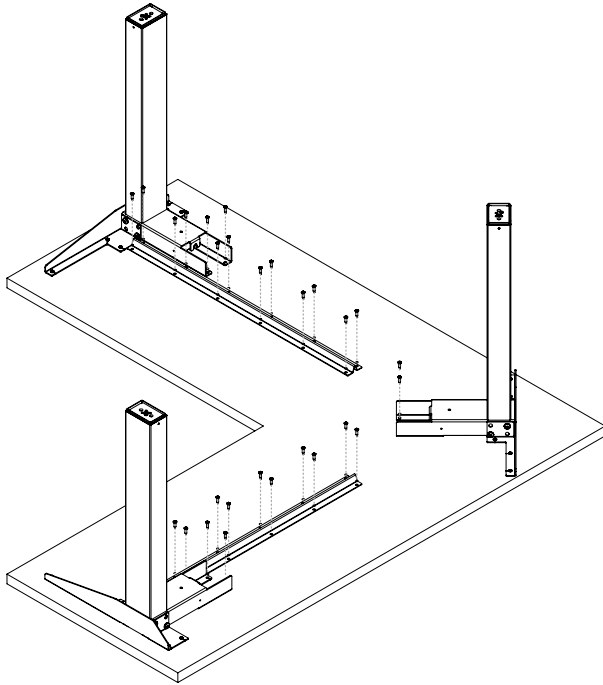

TOP SIZE **A**

24in 8in
30in 14in

TABLE LENGTH **B**

72in

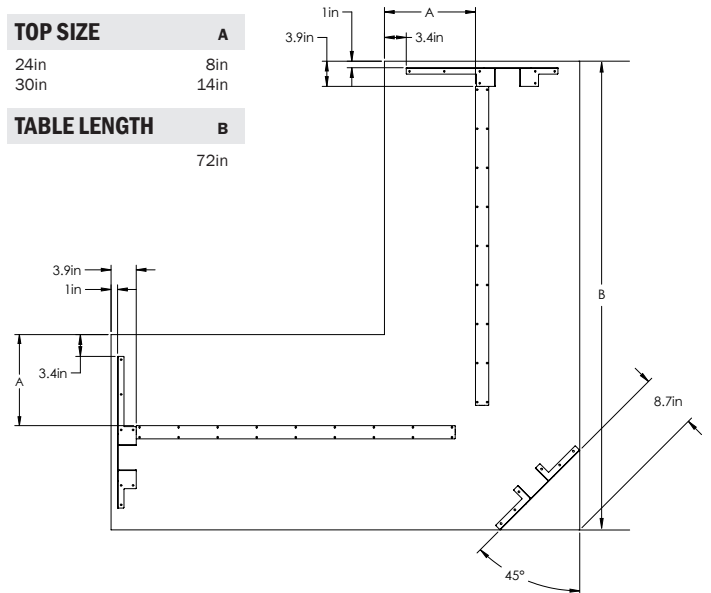

THREE-LEG: 120 DEGREE

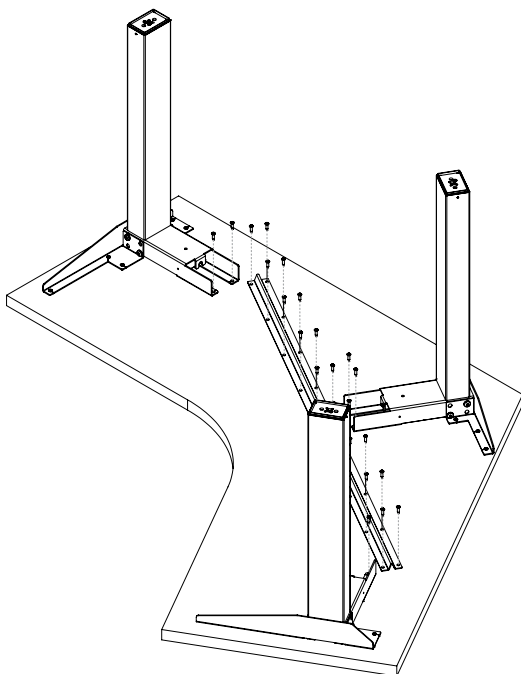
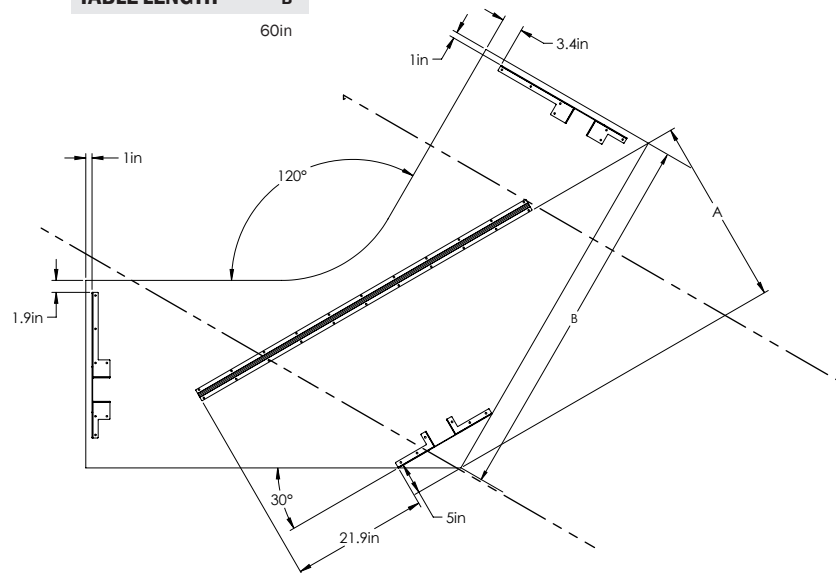

TABLE DEPTH **A**

24in 24in
30in 30in

TABLE LENGTH **B**

60in



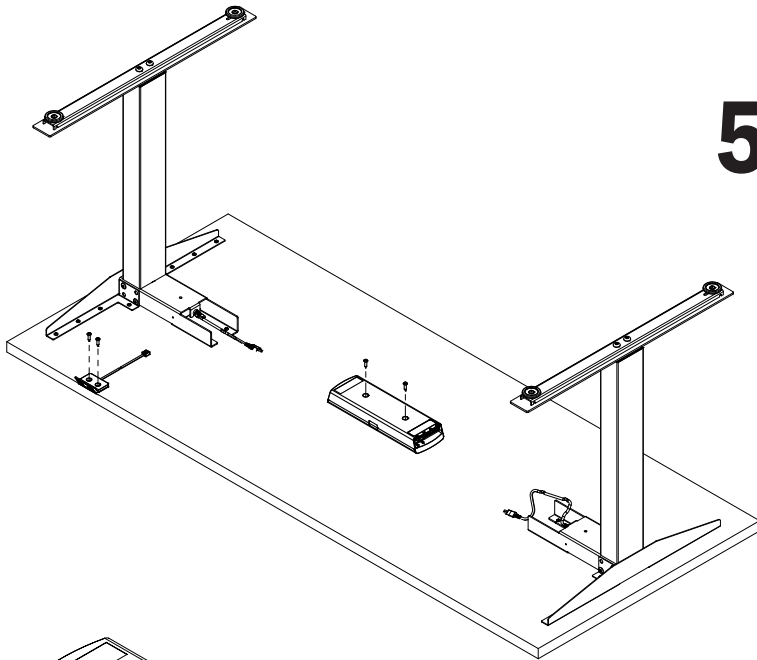

5 FASTEN THE CONTROL BOX AND HANDSWITCH TO THE TABLE TOP

Make sure the control box and handswitch are fastened in a location where all the cables will connect without being in tension. Be sure to use approved screws per the table top supplier.

6A CONNECT THE COLLISION SENSOR TO THE CONTROL BOX INSTRUCTIONS (OPTIONAL)

(The sensor can be connected to either the D1 or D2 port of the control box)

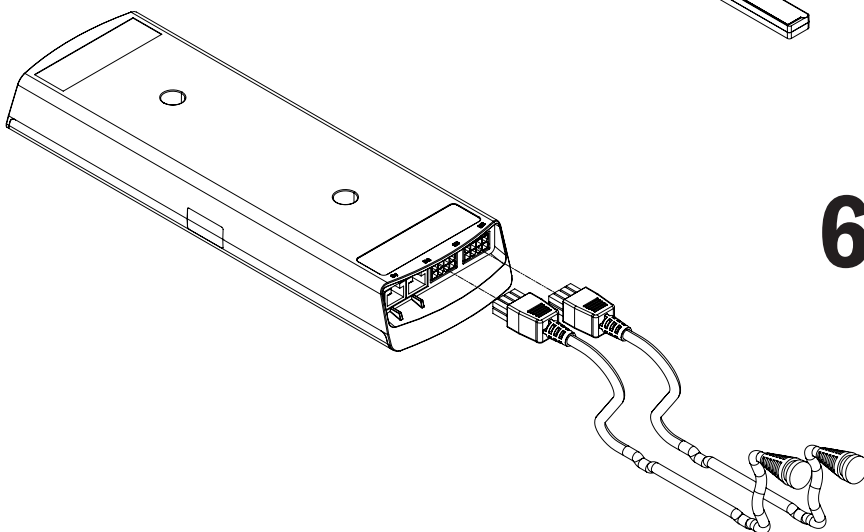
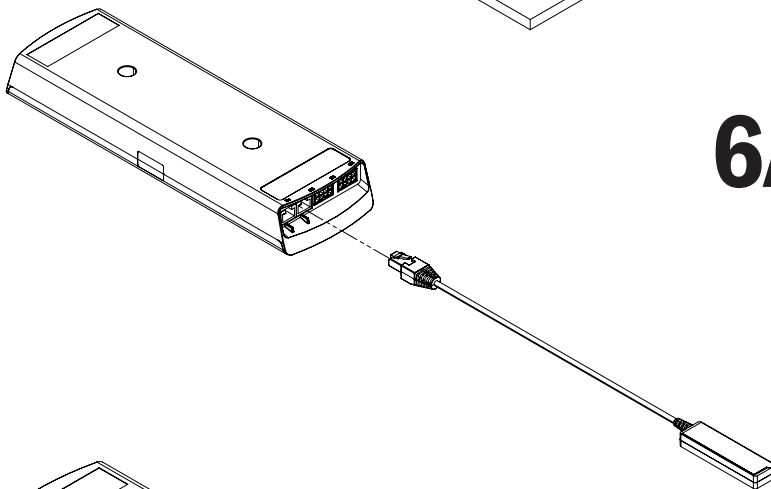

6B CONNECT THE MOTOR CABLES TO THE CONTROL BOX

The motor cable plug-connection has to click into place.

Connections to the control box:

M1-M2 = Connectors for the columns

D1 or D2 = Connectors for the handset

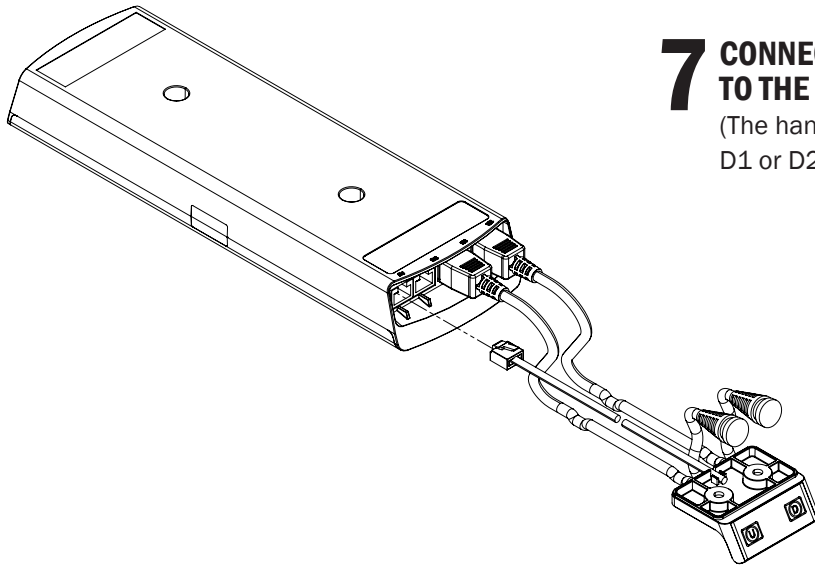

7 CONNECT THE HANDSWITCH (HS) CABLE TO THE CONTROL BOX

(The handswitch can be connected to either the D1 or D2 port of the control box)er.

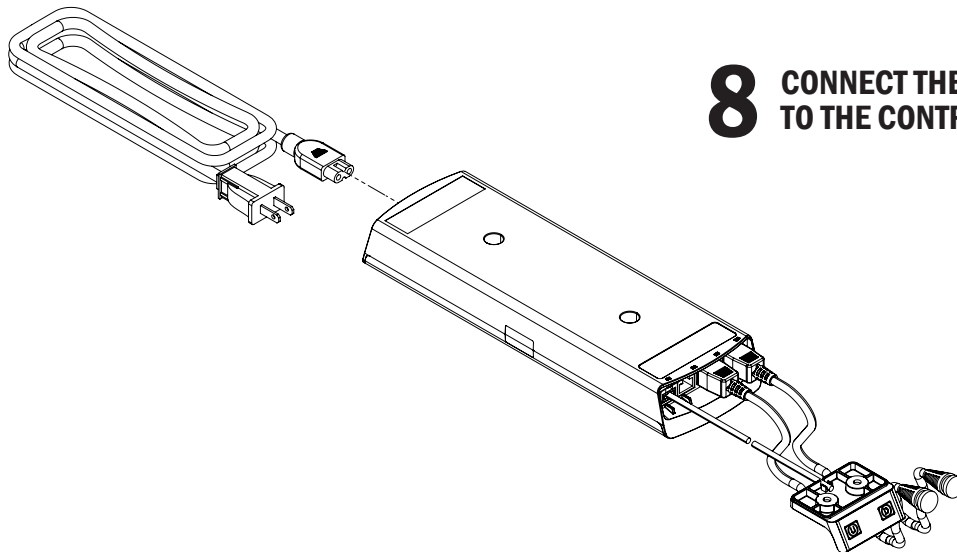

8 CONNECT THE SUPPLIED POWER CORD (AC) TO THE CONTROL BOX

9 ATTACH ALL CABLES TO THE TABLE FRAME OR ON THE UNDERSIDE OF THE WORK SURFACE

Attach cables in order to avoid any damage during operation.
Never wrap cables and/or cords around the columns.

OPERATION INFORMATION

INITIALIZATION/RESET

The desk must be initialized/reset after any of the following:

- After assembly
- After disconnection from the power supply
- After any impact on the table top.

To initialize/reset, move the table to the lowest position by pressing the DOWN button on the handswitch until the columns reach the lowest position. Press the DOWN button again until the table moves slightly down to the machine zero point and back up to the operation zero point. Release the DOWN button. If the button is released too soon, the table legs will not move up. Repeat the reset process.

The control box is programmed with a parameter file which controls the table legs' lower and upper travel limits. **Under no circumstance should a control box from one table be moved to another.**

NORMAL HANDSWITCH OPERATION (for all handswitch types)

By pressing the UP or DOWN buttons, the table will move up or down to the desired position. Once the desired position is reached, let go of the UP or DOWN button. The table legs will stop once they reach the lower or upper height limits.

PROGRAMMABLE HANDSWITCH OPERATION (optional)

This programmable handswitch is equipped with a display for showing the current table height in Centimeters or inches.

The handswitch also will display an error code if an error is detected by the control box. When an error is detected, the display will show an error code "EXX," instead of the current table height. To resolve the error, see the Troubleshooting Section of this guide.

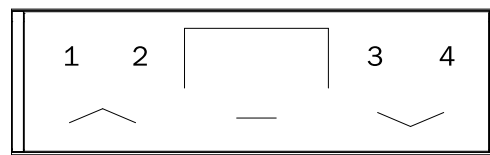

The programmable handswitch also has the ability to save up to four different height positions.

CHANGE THE HEIGHT UNIT (inches or centimeters)

The handswitch can display the table height in either centimeters or inches. With the help of the F1 menus, the unit of measure can be changed.

To change the unit of measure, follow these steps:

1. Press and hold the (Center/— button) until "F" appears
2. Using the UP button cycle through the menu for "F1" and press the (Center/— button)
3. Choose between "I" for inches or "C" for centimeters and press the (Center/— button) to select.

PROGRAMMABLE HANDSWITCH OPERATION *(continued)*

To exit the menu without making a selection, wait until the height display appears again.

CHANGE THE HEIGHT DISPLAY

If the displayed value does not match the actual height of the table top, the display can be corrected as follows:

1. Press and hold the (Center/— button) until “F” appears
2. Using the UP button cycle through the menu for “F2” and press the (Center/— button)
3. Use the UP/DOWN buttons to adjust to the desired height display and press the (Center/— button) to save.

To exit the menu without making a selection, wait until the height display appears again.

SAVE MEMORY POSITION

1. Move the table up or down to the desired height.
2. Press the center button/— (in the display “P-” is shown)
3. Select a position by pressing one of the four number buttons, 1-4, (the display will show the setting as “P1”).
4. The saved position is confirmed by a double click sound from the control box. The display shows the current table height. Repeat steps to save a maximum of four different positions.







To exit the menu without making a selection, wait until the height display appears again.

RECALL MEMORY POSITION

Press and hold the desired memory button (1, 2, 3 or 4) the table moves from the current position into the saved position. The button must be pressed until the position is reached. If the button is released, the table will stop short of the desired height.

SENSITIVITY ADJUSTMENT FOR EXTERNAL COLLISION SENSOR

The sensitivity can be adjusted separately for the optional external sensor (STAND.GUARD G1), each for up and down travel.

1. Go to the menu of the hand switch in accordance with the instructions.
2. Navigate with the arrow keys ( and ) to the...
menu option 8, display shows:  for the external sensor (STAND.GUARD G1) drive up or
menu option 9, display shows:  for the external sensor (STAND.GUARD G1) drive down
3. Confirm the selection by once again pressing the “Logo” key.
4. Use the arrow keys ( and ) to adjust the displayed sensitivity in % to the desired percentage:
 - a. 0% (OFF) to
 - b. 99% (very sensitive)
5. Pressing the "Logo" button again saves the displayed value. Alternatively, wait approx. 10 seconds to cancel the function and to return to the menu.

Warning: The sensitivity of the external sensor should only be changed by trained personnel. By reducing the sensitivity, collisions may possibly be detected later or not at all.

The factory-set default values in the controller were selected so that the collision forces are below 150N for a maximum of 5 seconds and then only 25N. If the sensitivity is reduced, the approval according to EN ISO 12849-1 expires.

SHELF AND CONTAINER STOPS

Container and shelf stops are safety positions that cannot be run over during normal operations, so that collisions with known, permanently present hindrances can be prevented. The container stop limits the movement height downwards (minimum height) and the shelf stop limits the movement height of the table upwards (maximum height). If an attempt is made to set the container stop or shelf stop too close to the middle, the controller signals this with 6 quiet click sounds. **Note: This function is configuration-dependent and is not available with every controller. With the additional stops, the safety of the table system can be increased, in that the possible movement path is restricted.**

SET UP SHELF AND CONTAINER STOPS

Move the table using the arrow keys into the desired position. Press **both** arrow keys at the same time. The controller confirms with a quiet, double-click. The absence of this signal means that setting is possibly not permitted.

DELETE THE CONTAINER STOP

Keep the **down** arrow key pressed. The table stops automatically upon reaching the container stop. Press **both** the arrow keys at the same time. The controller confirms with a quiet, double-click.

DELETE THE SHELF STOP

Keep the **up** arrow key pressed. The table stops automatically upon reaching the container stop. Press **both** the arrow keys at the same time. The controller confirms with a quiet, double-click.

WARNING: With an initialization movement prompted by the controller, the reset position is always approached directly. Any container stop or safety stop that is present is ignored.

First, remove all hindrances below the table and pay heed to the increased risk of injury.

Only trained personnel should carry out setting and deletion of container and shelf stops. There is a danger of injury from wrong setting or removal of the Stop positions, and a danger of the table getting destroyed.

TROUBLESHOOTING

EASY TO RECTIFY FAULTS

WARNING: Before troubleshooting, especially on possibly faulty cables, the controller must be isolated from the network.



If a fault cannot be described, isolate the product from the voltage supply, wait for at least 3 minutes and try again. If the fault continues to occur after the initialization run, isolate the product from the voltage supply and contact customer service.

UNIT

FAULT DESCRIPTION	TROUBLESHOOTING
Table does not move	Check whether the controller has power
	Check the connection between the drives and the controller(s). Restore the connections.
	Check the loading of the table. Reduce the weight on the table.
	Powering-on duration exceeded. Wait until the table is ready for use again (approx. 3 min)
	Drive defective: Contact customer service.
	Controller defective: Contact customer service
	Defective control box: Contact customer service
	Handswitch faulty: Replace the handswitch or contact customer service.
	Carry out an initialization movement.
Table is not moving, but moved earlier	Table is at a slant: Carry out an initialization run
	Table leg was separated: Check all the connections and carry out an initialization movement.
	Powering-on duration was exceeded: Wait until the table is ready for use again.
Table stops abruptly	Powering-on duration was exceeded: Wait until the table is ready for use again.
	Check the loading of the table. Reduce the weight on the table
Table stops abruptly and moves back	Collision protection has been triggered: Remove the hindrance and try it again.
Table moves slowly and downwards only	Table is in an initialization movement: Continue it up to the end.
Table only moves briefly on one side and than remains stationary	Table is below the safety stop (downward movement slow; upward movement at normal speed): Move upwards, out of this zone
	Drive defective: Contact customer service
Table moves slowly	Table is below the safety stop (downward movement slow; upward movement at normal speed): Move upwards out of this zone.
	Check the loading of the table. Reduce the weight on the table

ACOUSTIC CODES

The controller, as soon as it is supplied electric power, can give the user information about the current system status by means of its integrated relay.

# OF DOUBLE CLICK SOUNDS	WHEN	STATUS INFORMATION
1	Supply of electrical power (Dependent on configuration)	Normal Operation: The system is functioning without any problems. Faulty Operation: The controller does not have any firmware: only 1 click sounds
1	Up key pressed	Reset: Initialization movement is required
1	Lower blockade detected	Reset: Table has reached the Reset position during the initialization movement. The  key can be released
1	Lower blockade detected	Reset: Initialization movement has ended;  key continues to be pressed. Release the key
2	Set container or shelf stop	Confirmation: The position was successfully saved
3	First movement after sensor out	Caution: A previously detected sensor has been removed. Normal operation can continue.
3	First movement after sensor reinserted	Note: A sensor was reconnected after a previously detected sensor had been removed. Normal operation can continue.
4	Delete container or shelf stop	Confirmation: The position was successfully deleted.
6	Container stop or shelf stop too near in the middle	Warning: An attempt is being made to set the container stop or shelf stop too near the middle of the total stroke
7	Motor cable pulled or missing	Warning: Motor cable absent when connecting to the mains, or has been disconnected during operation. Connect the missing motor cable with the controller.
7	Table moves at an angle	Warning: Slanted position of the table has become too big. Carry out an initialization movement.

If it is not possible to resolve an error as described, disconnect the power cord, wait a few minutes and reset the table again. If the error still occurs, remove the table from the power source and contact customer service.
(Error Code list is valid from firmware 1.7.5 and higher)

VISUAL CODES

Visual codes can only be used with using handswitch models with a display.

DISPLAY	DESCRIPTION	REMEDY	DISPLAY AFTER TROUBLESHOOTING
C01	Short circuit motor 1	Pull out the mains plug! Remove the external short circuit, check the cables to the motors for possible damage or plug the correct motor into the socket concerned. Put the control back into operation.	001-999 Normal height display
C02	Short circuit 2 motor 2		
C05	Relay contact is sticking	Replace the controller	C38 An initialization run is required
C11	Cable of motor 1 is pulled	Check the cable or plug connection to the motors	C38 An initialization run is required
C12	Cable of motor 2 is pulled		
C15	No pulses measurable	Check the cables to the motors for possible damage and secure contact or, if necessary, replace the motor at the relevant socket. Put the controller back into operation.	C38 An initialization run is required
C34	Over current at motor 1	Max load exceeded, remove the load from the table	00001-999 Normal height display
C35	Over current at motor 2		
C38	The motors have lost sync. An initialization run is required	Motor positions too different. Distribute the load more evenly on the table. If necessary, reduce the load on the table. Perform an initialization run.	001-999 Normal height display
C39	Cascading error controlling is not communicating	Check whether the STAND. CONNECT connection cable between the controllers is correctly plugged in and a power cable is plugged into both controllers.	001-999 Normal height display
		Use the F3 menu to restore the factory settings in order to carry out a reconfiguration.	C38 An initialization run is required
C40	Sense module error	Further movements are made without collision protection. Movement remains possible. Check sensor module.	001-999 Normal height display
C51	Contradictory movement commands	Stop operation at all present handswitches	001-999 Normal height display
C52	The  key on the hands switch is stuck	Replace handswitch	001-999 Normal height display

VISUAL CODES

Visual codes can only be used with using handswitch models with a display.

DISPLAY	DESCRIPTION	REMEDY	DISPLAY AFTER TROUBLESHOOTING
C53	The  key on the handswitch is stuck	Replace handswitch.	001-999 Normal height display
C81	Voltage too small	Can occur after disconnecting the power cord.	001-999 Normal height display
		Main defective, replace controller.	C38 An initialization run is required
C82	Voltage is too high	Main defective, replace controller	C38 An initialization run is required
C84	No columns connected when the controller is switched on	First connect the desired number of columns and handswitches and use the F3 menu to restore the factory settings	C38 An initialization run is required
C85	Number of columns does not match the current configuration	Check the motor cables or use the F3 menu to restore the factory settings	C38 An initialization run is required
REF	Initialization run is carried out.	Perform the initialization run to the lowest block position..	001-999 Normal height display
SP	System protection/ system pause. The powering-on duration of the system was exceeded.	Wait until the controller has cooled and the display SP turns off. Then, the movement duration of 17 seconds is cleared. Only after 18 minutes does the table move again for a full 2 minutes. ATTENTION: The calculation of the powering on duration is performed even if there is no mains voltage present.	001-999 Normal height display
COL	Collision detected	Remove the hindrance.	001-999 Normal height display after moving off in one direction
CAL	Sensor calibrated	Leave table alone	001-999 Normal height display
001-999	The table moves; height display		

TECHNICAL DATA

GENERAL CONTROL BOX	
Power supply	120 VAC ±10% / 60 Hz
Standby power consumption, primarily	<0.3 W
Operating temperature	0-35° C
Protection class	IP 20
Maximum power output	250W/ 31VDC

TWO-COLUMN FRAME WITH CONTROL BOX	
Maximum lift capacity	200 lb (≈ 90 kg / 890N)
Adj. range, depending on version	View Illustration B
Maximum input current	5 A
Maximum duty cycle	10% (2 min. on / 18 min. off)

THREE-COLUMN FRAME WITH CONTROL BOX	
Maximum lift capacity	250 lb (≈ 113 kg / 1112N)
Adj. range, depending on version	View Illustration B
Maximum input current	6.5 A
Maximum duty cycle	10% (2 min. on / 18 min. off)

ILLUSTRATION B

SINGLE STAGE

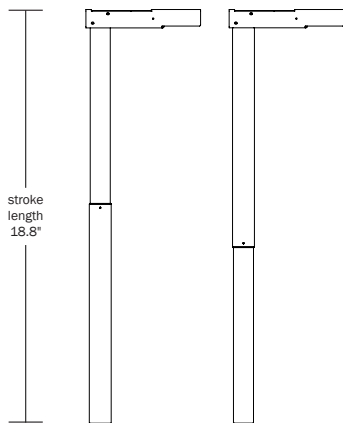

DUAL STAGE

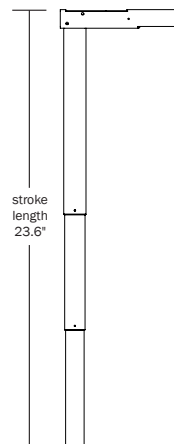

DUAL STAGE LOW

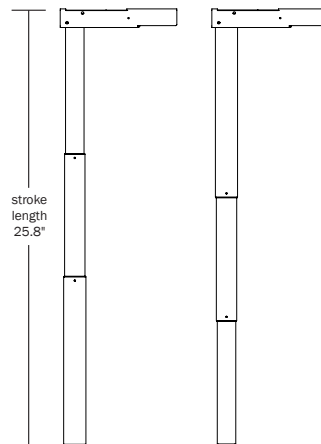

STANDARDS & CERTIFICATIONS

The drive system is tested according to the following standards:

UL 962

Issued: 2014/11/07 Ed: 4 Household and Commercial Furnishings

CSA C22.2#68

Issued: 2009/09/01 Ed: 7 (R2014)

Motor-Operated Appliances (Household and Commercial)

Meets BIFMA X5.5 2014.

WARRANTY

CONTACT YOUR SALES REPRESENTATIVE FOR WARRANTY INFORMATION

INTERTEK LISTING BELONGS TO:

System: Clever
OMT-Veyhl USA
11511 James Street
Holland, MI 49424



End of life cycle: Once product is disassembled, all steel components can be recycled at your local metal collector. For products with electronic components, see Disassembly Guide.

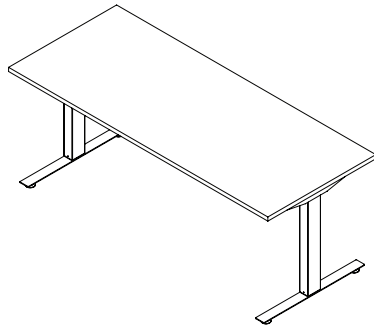

USER GUIDE